

LEGEND

HPG	High pressure gauge (Opt)
LPG	Low pressure gauge
MW	Water pressure gauge
RM	Manual water filling cap
SFA	Manual air vent
VSC	Water drain valve
ATV	Rubber type antivibrant mounting (Opt)

LIFTING AND CARRIAGE PRECAUTIONS

- Check the weight on the CE label to select appropriate lift equipment .
- Before lifting the unit make sure that the external panel is firmly fixed in place.
- To use only lifting points provided.
- The chains or slings must be of equal length.
- To use a spread-bar to avoid damage to the unit.
- The movement must be performed with caution and avoid abrupt movements.
- Never move the unit on rollers.

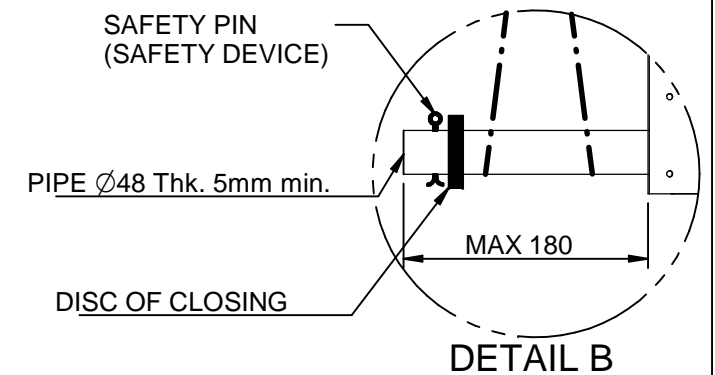
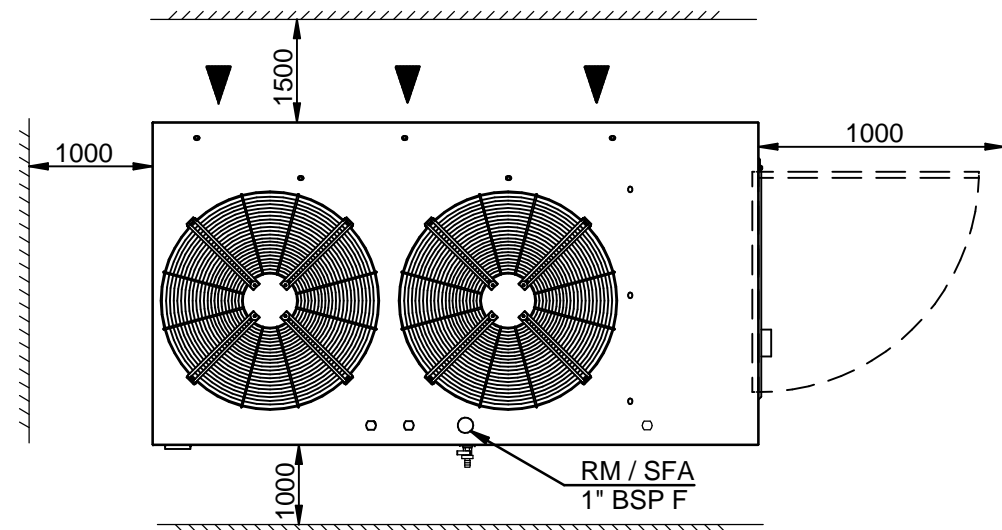

MOD.	EMPTY WEIGHT	OPERATING WEIGHT
ENR.030	375 kg	675 kg
ENR.038	390 kg	690 kg
ENR.045	410 kg	710 kg
ENR.055	500 kg	800 kg

Scala-Scale	Data-Date	Dis.to-Drawn	N°Pezzi
	11/04/13	M. M.	
Peso-Weight Kg.	Materiali-Materials		
Denominazione-Denomination			
WATER CHILLERS mod. ENR.030÷055			
Particolare-Detail			
Overall dimension - Lift Instruction			
REFRIGERANT R410a			

HITEMA®

DIS.-DRAW N.	DIM-ENR-030ST01
Rev.	08-M.M.-29/12/16
PROGRAM.N.	